

Online Anfrageformular

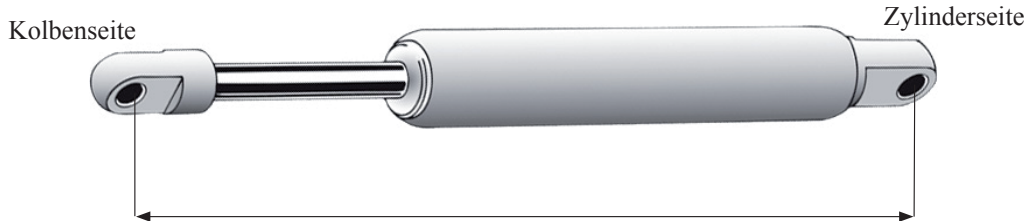

1= Kolben

2= Zylinder

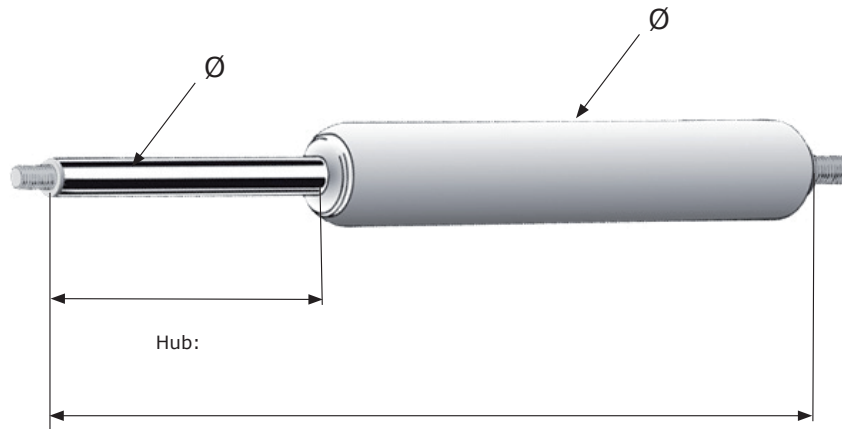

Gelenkauge



Auge



Winkelgelenk



Gabel



Axialgelenk



Bodenstück

Material (Stahl / V2a / V4a) :

Ausschubkraft / N

Hub / mm

Ø Kolbenstange

Ø Zylinderrohr

Einbaulänge 1 (o. Anschlüsse)

Einbaulänge 2 (mit Anschlüssen)

Anschluß Kolbenseite

Anschluß Zylinderrohrseite

Ventil gewünscht :

Menge :

Firma:

Kontakt:

Adresse:

Tel./Fax:

PLZ/Ort

eMail: